

104**QUESTION BOOKLET****Post: Jr. Engineer (Electrical)****INSTRUCTIONS**

Q.B. Number:

Roll Number:

--	--	--	--	--	--	--	--	--	--

Q.B. Series: **B**

Please read the following instructions carefully.

1) Mark carefully your Roll Number, Question Booklet Number and series of the paper on the OMR Answer Sheet and sign at the appropriate place. Write your Roll number on the question booklet.

2) Strictly follow the instructions given by the Centre Supervisor / Room invigilator and those given on the Question Booklet. Please ensure you fill all the required details and shade the bubbles correctly on the OMR Answer Sheet.

3) Please mark the right responses ONLY with Blue/Black ball point pen. USE OF PENCIL AND GEL-PEN IS NOT ALLOWED.

4) Candidates are not allowed to carry any papers, notes, books, cellular phones, scanning devices, pagers etc. to the Examination Hall. Any candidate found using, or in possession of such unauthorized material, indulging in copying or impersonation or adopting unfair means, is liable to be summarily disqualified and may be subjected to penal action.

5) After finishing the examination, hand over the complete question booklet and the OMR Answer Sheet. DO NOT carry the question booklet or any part of it, outside the examination room. Doing so, is a punishable offence.

6) The test is of objective type. This Question Booklet contains a total of 150 questions and the total time allotted is 2 hours 30 minutes.

7) Each objective question is followed by four responses. Your task is to choose the correct response and mark your response on the OMR Answer Sheet and NOT on the Question Booklet.

8) All questions are compulsory. There will be no NEGATIVE MARKING.

9) For each answer as shown in the example below. The CORRECT and the WRONG method of darkening the CIRCLE on the OMR sheet are given below.

Correct Method



Wrong Method



10) In view of the tight time span, do not waste your time on a question which you find to be difficult. Go on solving questions one by one and come back to the difficult questions at the end.

11) DO NOT make any stray marks anywhere on the OMR Answer Sheet. DO NOT fold or wrinkle the OMR Answer Sheet. Rough work MUST NOT be done on the answer sheet. Use your question booklet for this purpose.

1. A galvanised steel tower member has original length of 22cm and cross sectional area of 13 cm². With working axial tensile load of 125 KN, the change in length was 0.2 mm. Calculate the percentage of elongation.
(A) 0.0712%
(B) 0.00612%
(C) 0.0909%
(D) 0.19%
2. A Transmission line conductor has been suspended freely from two towers and has taken the form of a catenary that has $c = 487.68\text{m}$. The span between the two towers is 152 m, and the weight of the conductor is 1160 kg/km. Calculate the length of the conductor.
(A) 487.68 m
(B) 152.614 m
(C) 5.934 m
(D) 11.9 m
3. We wish to build a 135 V, 20 A, DC power supply using a single phase bridge rectifier and an inductive filter. The peak to peak current ripple should be about 10%. If a 60 Hz AC source is available; Calculate the peak to peak current ripple.
(A) 19 A
(B) 20 A
(C) 2 A
(D) 1 A
4. An alternator is feeding an infinite bus bar. Its prime mover is suddenly shut down. The alternator will:
(A) Continue to work as alternator but the direction of rotation will reverse.
(B) Come to stand still.
(C) Continue to work as synchronous motor and direction of rotation will also be same.
(D) Will work as an induction motor.
5. What is the dimensional representation of Power?
(A) ML^2T^{-3}
(B) $M^2L^2T^{-3}$
(C) MLT^{-3}
(D) M^2LT^{-2}
6. Internal resistance of a cell depends on
(A) Terminal voltage
(B) Torque
(C) Current
(D) Area of the plates
7. A parallel combination of capacitance C and resistance R is connected in series with inductance L and small resistance r. Under what condition will the circuit be non-reactive?
(A) $C=LR$
(B) $C=LR^2$
(C) $C=L/R^2$
(D) $C=L/R$
8. A metal oxide varistor (MOV) is used for protecting:
(A) Gate circuit against over currents
(B) Gate circuit against over voltages.
(C) Anode circuit against over currents.
(D) Anode circuit against over voltages.
9. Which one among these is an example for trivalent impurity?
(A) Phosphorus
(B) Antimony
(C) Gallium
(D) Arsenic
10. Copper shading is provided in energy meter to
(A) Bring flux exactly in quadrature with applied voltage
(B) To increase speed of aluminium disc
(C) To count the rotation
(D) To balance the system from vibration

11. Which of the following testing methods is a direct testing of D C machine?
- (A) Swinburne's Test
(B) Field Test
(C) Hopkinson's Test
(D) Brake Test
12. The reciprocal of resistance is called
- (A) Impedance
(B) Conductance
(C) Inductance
(D) Susceptance
13. In order to recover the original signal from the Sampled one, what is the condition to be satisfied for sampling frequency ω_s and highest frequency component ω_m ?
- (A) $\omega_m < \omega_s \leq 2 \omega_m$
(B) $\omega_s \geq 2 \omega_m$
(C) $\omega_s < \omega_m$
(D) $\omega_s = \omega_m$
14. What is the purpose of providing a fuse in an electric circuit?
- (A) To safe guard the installation against heavy current
(B) To reduce the current flowing in the circuit
(C) To reduce the power consumption
(D) To improve power factor
15. The differential coupling of two coils in series connection has self-inductance of 2 mH & 4 mH & a mutual inductance of 0.15 mH. The equivalent inductance of the combination is:
- (A) 5.7 mH
(B) 5.85 mH
(C) 6 mH
(D) 6.15 mH
16. The capacitance of 0-1000V electrostatic voltmeter increases from 36-42 pF from zero to full scale deflection. It is required to extend the range of voltmeter to 10000 V by using an external series capacitor. What should be the value of series capacitor?
- (A) 0.8 pF
(B) 1.00 pF
(C) 6.644 pF
(D) 4.667 pF
17. In which type of the faults given below, all of the three components I_{a0} , I_{a1} and I_{a2} are equal?
- (A) Single line to ground fault
(B) Double line to ground fault
(C) Line to line fault
(D) 3 phase faults
18. For a fault at terminals of the synchronous generator, the fault current is maximum for a:
- (A) Three phase fault
(B) Double line to ground fault
(C) Line to line fault
(D) Line to ground fault
19. The nodal method of circuit analysis is based on
- (A) KVL and ohms law
(B) KVL and KCL
(C) KCL and ohms law
(D) Thevenins theorem
20. Bohr Magneton is unit of:
- (A) Magnetic energy
(B) Permanent dipole moment due to spin
(C) Polarisability
(D) Hysteresis
21. A conductor is composed of seven identical copper strands, each having a radius 'R'. Then what is self GMD (Geometric Mean Distance) of the conductor?
- (A) 2.645 R
(B) 2.177 R
(C) 2.141 R
(D) 1.21 R
22. A system function has a pole at $s=0$ and a zero at $s=-1$. The constant multiplier is unity. For an excitation $\cos(t)$, What is the steady-state response?
- (A) $\sqrt{2}\sin(t+45^\circ)$
(B) $\sqrt{2}\sin(t-45^\circ)$
(C) $\sin(t-45^\circ)$
(D) $\sin(t)$

23. The radix of binary number is
(A) 1
(B) 0
(C) 2
(D) 8
24. Norton's Theorem is a way to reduce a network to
(A) An equivalent circuit composed of a single current source, series resistance, and series load
(B) An equivalent circuit composed of a single voltage source, parallel resistance, and parallel load
(C) An equivalent circuit composed of a single voltage source, series resistance, and series load
(D) An equivalent circuit composed of a single current source, parallel resistance, and parallel load
25. What is the minimum clearance of HV Lines from ground across streets?
(A) 3 meters
(B) 8 meters
(C) 6 meters
(D) 5 meters
26. In the solution of load flow equation, Newton Raphson (NR) method is superior to the Gauss-Seidal (GS) Method, because the:
(A) Convergence characteristic of the NR methods are not affected by selection of slack bus
(B) Number of iterations required in the NR method is not independent of the size of the system
(C) Time taken to perform one iteration in the NR method is less when compared to the GS method
(D) Number of iteration required in the NR method is more than compared to that in the GS method
27. The current $i(t)$, through a 10Ω resistor in series with an inductance, is given by $I(t) = 3 + 4\sin(100t + 450) + 4\sin(300t + 600)$ amperes. The RMS values of the current and power dissipation in the circuit are:
(A) $\sqrt{41}$ A, 410 W respectively
(B) $\sqrt{35}$ A, 350 W respectively
(C) 5 A, 250 W respectively
(D) 11 A, 1210 W respectively
28. Which of the following gate is called universal gate?
(A) AND
(B) NOT
(C) NOR
(D) EX-OR
29. A 200 V, 50 Hz inductive circuit takes a current of 10 A at 30 degree lagging pf, what is the inductive reactance of the circuit?
(A) 17.8Ω
(B) 100Ω
(C) 178Ω
(D) 10Ω
30. Calculate the approximate locked rotor current of a 3 phase induction motor having a rating of 500 Hp, 2300 V.
(A) 130 A
(B) 39 A
(C) 390 A
(D) 780 A
31. For a two port network to be reciprocal:
(A) $Z_{11} = Z_{22}$
(B) $Y_{21} = Y_{12}$
(C) $h_{21} = h_{12}$
(D) $AD - BC = 0$
32. If each branch of a Delta circuit has impedance $\sqrt{3} Z$, then each branch of the equivalent Y circuit has impedance:
(A) $Z/\sqrt{3}$
(B) $3Z$
(C) $3\sqrt{3}Z$
(D) $Z/3$
33. The measurement of dielectric loss and power factor is done using
(A) Weins Bridge
(B) Hays Bridge
(C) Schering Bridge
(D) Wheat Stone Bridge

34. In the measurement of three phase power by two wattmeter method, if the two wattmeter readings are equal then power factor of the circuit is
- (A) 0.8 lag
 - (B) Unity
 - (C) 0.8 lead
 - (D) Zero
35. What is the required connection for an enhancement type N-MOSFET to function as a resistor?
- (A) Gate connected to sources
 - (B) Gate connected to drain
 - (C) Drain connected to sources
 - (D) Source open-circuited
36. The hysteresis loop of magnetic material has an area of 5 cm^2 with the scales given as $1 \text{ cm}=2\text{AT}$ and $1 \text{ cm}=50 \text{ mWb}$, at 50 Hz, the total hysteresis loss is
- (A) 15 W
 - (B) 20 W
 - (C) 25 W
 - (D) 50 W
37. What would be the total power drawn from the supply, when two heaters, rated at 1000 W, 250 V each are connected in series across a 250 V, 50 Hz supply?
- (A) 1000 W
 - (B) 500 W
 - (C) 250 W
 - (D) 2000 W
38. Byte is string of how many bits?
- (A) Eight
 - (B) Four
 - (C) Two
 - (D) Sixteen
39. A 30 MVA, 15 KV, 1500 rpm, 3 phase synchronous generator connected to a power grid has a synchronous reactance of 9 ohm per phase. If the exciting voltage is 12 kV (line to neutral) and the system voltage is 17.3 kV (line to line), Calculate the maximum power that generator can deliver before it falls out of step (losses synchronous).
- (A) 39.952 MW
 - (B) 78.349 MW
 - (C) 16.67 MW
 - (D) 112.89 MW
40. The stator of a 3 phase, 10 pole induction motor possesses 120 slots. If a lap winding is used, calculate the coil pitch, if the coil width extends from slot 1 to slot 11.
- (A) 72.12%
 - (B) 83.30%
 - (C) 12%
 - (D) 42%
41. According to Biot-Savart's laws the magnetic field at a point due to incremental element of length dl carrying a current is
- (A) Inversely proportional to the current carried by the element
 - (B) Directly proportional to the current carried by the element
 - (C) Directly proportional to the square of the distance
 - (D) Inversely proportional to the length of the element
42. Ward - Leonard controlled DC drives are generally used for:
- (A) Light duty excavators
 - (B) Medium duty excavators
 - (C) Heavy duty excavators
 - (D) Low duty excavators
43. What is the main drawback of the underground transmission system compared to the overhead transmission system?
- (A) Exposure to lightning
 - (B) Heavy initial cost
 - (C) Exposure to atmospheric hazards such as smoke, ice, wind
 - (D) Induction interference between power and communication circuits

44. An op-amp having a slew rate of 62.8 V/msec, is connected in a voltage follower configuration. If the maximum amplitude of the sinusoidal input is 10 V, then the minimum frequency at which the slew rate limited distortion would set in at the output is
- (A) 1 MHz
(B) 6.28 MHz
(C) 10 MHz
(D) 62.8 MHz
45. For a transient stability analysis, as long as equal area criterion is satisfied, the maximum angle to which rotor angle can oscillate is:
- (A) 0° to 20°
(B) 45° to 50°
(C) Greater than 90°
(D) 65° to 85°
46. What is the Bode amplitude plot of a first-order low-pass system?
- (A) Line with slope -40 dB/decade
(B) Line with slope -20 dB/decade
(C) Line with slope +20 dB/decade
(D) Straight line parallel to the frequency axis
47. What is the energy stored in the magnetic field at a solenoid of 40 cm long and 4 cm diameter wound with 100 turns of wire carrying a current at 20A?
- (A) 0.705 Joule
(B) 0.789 Joule
(C) 0.587 Joule
(D) 0.658 Joule
48. A single phase 60 Hz generator supplies an inductive load of 4500kW at a power factor of 0.80 lagging by means of a 20 km long overhead transmission line. The line resistance and inductance are 0.0195 ohm and 0.60 mH per km. The voltage at the receiving end is required to be kept constant at 10.2 kV. Find the voltage regulation of the line.
- (A) 12.59%
(B) 16.34%
(C) 32.68%
(D) 41.15%
49. Two's complement of -8 is
- (A) 1000
(B) 1010
(C) 110
(D) 1110
50. A 150 kW electric motor has an efficiency of 92 %, when it operates at full load. Calculate the losses in the machine.
- (A) 92 kW
(B) 150 kW
(C) 163 kW
(D) 13 kW
51. A 30 MVA, 13.2 KV synchronous generator has a solidly grounded neutral. Its positive, negative and zero sequence impedances are 0.30, 0.40 and 0.05 pu respectively. What value of reactance must be placed in the generator neutral so that the fault current for a line to ground fault of zero fault impedance shall not exceed the rated line current.
- (A) 4.416 ohm
(B) 8.8 ohm
(C) 2.08 ohm
(D) 10.2 ohm
52. A three phase transmission line delivers a load of 5 MW at 0.8 power factor lagging. Resistance of each conductor is 0.5 ohm / km. Receiving end voltage is 33 kV. If the line loss is not to exceed 10%, determine the length of the line.
- (A) 7 km
(B) 27.9 km
(C) 56.8 km
(D) 13.9 km
53. If the load current and flux of a DC motor are held constant, and voltage applied across its armature is increased by 10%, its speed will:
- (A) Decrease by 10%.
(B) Remain unchanged.
(C) Increase by 10%.
(D) Increase by 20%.

54. A thyristor power converter is said to be in discontinuous when:
- The load current is zero even though the load voltage is present.
 - Both load voltage and load current are zero simultaneously.
 - The load current is present even though load voltage is zero.
 - When load current is ripple free.
55. What is essential for a successive approximation N-bit ADC?
- 2^N clock pulses for conversion, an up-down counter and a DAC.
 - N clock pulses for conversion, a binary counter and a comparator.
 - 2^N clock pulses for conversion and a binary counter only.
 - N clock pulses for conversion, an up-down counter and a DAC.
56. A single phase transformer rated at 3000 kVA, 69 kV / 4.16 kV, 60 Hz has a total internal impedance Z_p of 127 ohm, referred to the primary side. Calculate the primary current if the secondary is accidentally short circuited.
- 43.5 A
 - 543 A
 - 9006 A
 - 721 A
57. What is the equivalent resistance of one limb A when delta connection is transformed in to star?
- $R_1R_3/R_1+R_2+R_3$
 - $R_2R_3/R_1+R_2+R_3$
 - $R_1R_2R_3/R_1+R_2+R_3$
 - $R_1+R_2+R_3$
58. The sending and receiving end voltages of a three phase transmission line at 100 MW load are equal at 230 KV. The phase line impedance is $j14$ ohm. Calculate the maximum steady state power that can be transmitted over the line.
- 3778.5 MW
 - 2234.56 MW
 - 1784.19 MW
 - 512.37 MW
59. What is the pitch factor of a 4 pole alternator having 36 slots and a coil span of 1 to 8?
- 140°
 - 80°
 - 20°
 - 40°
60. What is the basic principle of operation of a transformer?
- Self-induction
 - Mutual-induction
 - Static-induction
 - Dynamic-induction
61. A single phase motor draws a current of 5 A from a 120 V, 60 Hz line. The power factor of the motor is 65%. Calculate the active power absorbed by the motor.
- 600 W
 - 390 W
 - 456 W
 - 650 W
62. A 60 Hz, 4 pole turbo generator rated 100 MVA, 13.8 KV has an inertia constant of 10 MJ/MVA. Find the stored energy in the rotor at synchronous speed.
- 10 MJ
 - 100 J
 - 1000 J
 - 1000 MJ
63. If the characteristics equation of a closed loop system is $s^2+2s+2=0$, then the system is
- Over damped
 - Critically damped
 - Under damped
 - Undamped

64. To Charge a 120 V battery from a 600 V DC source using a DC chopper, The average battery current should be 20 A, with a peak to peak ripple of 2 A. If the chopper frequency is 200 Hz, calculate the duty cycle.
- (A) 0.2
(B) 0.1
(C) 0.5
(D) 0.6
65. A choke coil having resistance $R\Omega$ and of inductance L Henry is shunted by a capacitor of C farads. The dynamic impedance of the resonant circuit would be:
- (A) R/LC
(B) C/RL
(C) L/RC
(D) $1/RLC$
66. The direction of rotation of hysteresis motor is determined by the:
- (A) Resistivity of the rotor material.
(B) Amount of hysteresis loss.
(C) Permeability of rotor material.
(D) Position of shaded pole w.r.t main pole.
67. Q- meter is based on characteristics of
- (A) Shunt resonant circuit
(B) Series-parallel circuit
(C) Series resonant circuit
(D) Inductive reactance circuit
68. A Reactor having an inductive reactance of 4 ohm is connected to the terminals of a 120 V AC generator. Calculate the power associated with the reactor.
- (A) 3.6 kvar
(B) 30 kvar
(C) 7.2 kvar
(D) 4.16 kvar
69. What type of insulators are used whenever the conductors are dead ended and there is a change in the direction of transmission line?
- (A) Shackle type
(B) Strain type
(C) Pin type
(D) Suspension type
70. A coil having 90 turns is connected to a 120 V, 60 Hz source. If the effective value of the magnetizing current is 4 A. Calculate the inductance of the coil.
- (A) 79.6 mH
(B) 121.2 mH
(C) 32.2 mH
(D) 83.16 mH
71. What is the nature of supply current in parallel RC circuit with reference to the voltage?
- (A) In phase
(B) Lags by 90 degree
(C) Leads by 90 degree
(D) Compensates and becomes zero
72. A 3 Phase, 60 Hz generator connected in Y connection, generates a line to line voltage of 23900 V. Calculate the peak line voltage.
- (A) 13800 V
(B) 33800 V
(C) 42300 V
(D) 23900 V
73. In a control system, moving a summing point right side to the block yields in
- (A) Multiplication of the $G(s)$ in the feedback path
(B) Multiplication of the $1/G(s)$ in the feedback path
(C) Addition of gain block
(D) Subtraction of gain block
74. Which of the following plants is suitable for peak load?
- (A) Diesel engine plant
(B) Steam power plant
(C) Nuclear power plant
(D) Hydro-electric plant
75. Which of the following power plants involves high initial cost in erecting?
- (A) Hydro-electric power plant
(B) Steam power plant
(C) Gas turbine power plant
(D) Nuclear power plant

76. A shunt motor rotating at 1500 r/min is fed by a 120 V source. The line current is 51 A and the shunt field resistance is 120 ohm. If the armature resistance is 0.1 ohm, calculate the current in the armature.
- (A) 1 A
(B) 51 A
(C) 50 A
(D) 12 A
77. A pulse transformer is used in a driver circuit to:
- (A) Prevent DC triggering.
(B) Shape trigger signal.
(C) Generate high frequency pulses.
(D) Provide isolation.
78. Fermi level is the measure of
- (A) Doping of electrons
(B) Probability of occupancy of electrons or holes
(C) Probability of occupancy of photons
(D) Probability of occupancy of wavelength
79. For measuring the frequency of an unknown A.C. source. Which of the following device is necessary to obtain a standard waveform?
- (A) Operational amplifier
(B) Astable multivibrator
(C) Schmitt trigger
(D) Monostable multivibrator
80. A Lissajous pattern on an oscilloscope has 5 horizontal tangencies and 2 vertical tangencies. The frequency of the horizontal input is 1000 Hz. What is the frequency of the vertical input?
- (A) 400 Hz
(B) 5000 Hz
(C) 4000 Hz
(D) 2500 Hz
81. Which of the following statements is CORRECT?
- (A) A grid-connected induction generator always supplies lagging reactive power to the bus.
(B) An overexcited synchronous motor draws current at a lagging power factor.
(C) An under excited synchronous generator connected to an infinite bus works at a leading power factor.
(D) The load angle of a synchronous machine is the angle between the excitation voltage and the load current.
82. The meter constant of a single phase 240 V induction watt hour meter is 400 revolutions per KWhr. The speed of the meter disc for a current of 10 A of 0.8 pf, lagging will be
- (A) 12.8 rpm
(B) 16.02 rpm
(C) 18.2 rpm
(D) 21.1 rpm
83. Which loss has least proportion in DC machines?
- (A) Armature copper loss
(B) Field copper loss
(C) Magnetic loss
(D) Mechanical loss
84. Which among the following is the equation for the number of independent loops for a network with n nodes and b branches?
- (A) $n-1$
(B) $b+n-1$
(C) $b-n+1$
(D) $b-n$
85. Determine the transformer tap ratios when the receiving end voltage is equal to the sending end voltage, the high voltage line operates at 220 kV and transmit 80 MW at 0.8 pf and the impedance of the line is $(40+j140)\text{ohm}$. Assume $t_{st}=1.0$
- (A) 0.8
(B) 0.9
(C) 0.7
(D) 0.6
86. Which of the following is a scalar quantity?
- (A) Electric field strength
(B) Electric displacement density
(C) Electric potential
(D) Force

87. What is a load cell?
(A) A strain gauge
(B) A photo voltaic cell
(C) A thermistor
(D) A pressure pick up device
88. What is the order of the characteristic equation of an armature controlled DC motor?
(A) First order equation
(B) Second order equation
(C) Zero order equation
(D) Third order equation
89. Error detector is also called as
(A) Multiplexer
(B) Decoder
(C) Comparator
(D) Integrator
90. Which of the following serves as donor impurity in Silicon?
(A) Boron
(B) Indium
(C) Germanium
(D) Antimony
91. A three phase breaker is rated at 2000 MVA, 33 kV, its making current is
(A) 70 kA
(B) 89 kA
(C) 49 kA
(D) 35 kA
92. Three single phase transformers are connected in delta-delta to step down a line voltage of 138 kV to 4160 V to supply power to a production plant. The plant draws 21 MW at a lagging power factor of 86 %. Calculate the apparent power furnished by the HV line.
(A) 24.4 MVA
(B) 48.8 MVA
(C) 12.2 MVA
(D) 6.1 MVA
93. A 750 Hp, 250 V, 1200 r/min DC motor is connected to a 208 V, 3 phase, 60 Hz, line using a 3 phase bridge converter. The full load armature current is 2500 A and the armature resistance is 4 m ohm. Calculate the required firing angle under rated full load conditions.
(A) 45 deg
(B) 208 deg
(C) 27 deg
(D) 32 deg
94. When a resistor R is connected to a current source, it consumes a power of 18 W. When the same R is connected to a voltage source having the same magnitude as the current source, the power absorbed by R is 4.5 W. The magnitude of the current source and the value of R are
(A) $\sqrt{18}$ A and 1Ω
(B) 3A and 2Ω
(C) 1A and 18Ω
(D) 6A and 0.5Ω
95. The transfer function of a phase lead compensator is found to be the form $(s+z_1) / (s + p_1)$ and that of a lag compensator to be of the form $(s+z_2) / (s + p_2)$. Then which of the following conditions must be satisfied?
(A) $z_1 > p_1$ and $z_2 > p_2$
(B) $z_1 > p_1$ and $z_2 < p_2$
(C) $z_1 < p_1$ and $z_2 < p_2$
(D) $z_1 < p_1$ and $z_2 > p_2$
96. Q factor is defined as the ratio of
(A) Resistance /inductance of reactive element
(B) Resistance/capacitance of reactive element
(C) Resistance to reactance of reactive element
(D) Resistance to susceptance of reactive element
97. Which test is used to determine the magnetizing impedance of a transformer?
(A) Short-circuit test
(B) Impulse test
(C) Load test
(D) Open- circuit test

98. What is the clock cycle time for a system that uses a clock with frequency of 150 kHz?
(A) 55 μ sec
(B) 5.5 μ sec
(C) 202 sec
(D) 6.6 μ sec
99. A 220 kV, 3 phase transmission line is 60 km long. The resistance is 0.15 ohm / km and the inductance is 1.4 mH / km. Use the short line model to find the power at the sending end when the line is supplying a three phase load of 300 MVA at 0.8 pf lagging at 220 kV.
(A) 5.58MW
(B) 80MW
(C) 85.58MW
(D) 74.42 MW
100. What happens to the angle between current and voltage, when a small capacitance is added in series with a highly inductive circuit?
(A) Increases
(B) Remains same as earlier angle
(C) Decreases
(D) Becomes indeterminant
101. What is the value of total electric flux coming out of closed surface?
(A) Zero
(B) Equal to volume charge density
(C) Equal to the total charge enclosed by the surface
(D) Equal to the surface charge density
102. In an instrument transformer the errors can be reduced by
(A) Using high reluctance core
(B) Using small cross sectional area
(C) Using low permeability materials
(D) Using low reluctance core
103. A 0.5 Hp, 6 pole wound rotor induction motor is excited by a 3 phase 60 Hz source. Calculate the frequency of the rotor current at standstill.
(A) 50 Hz
(B) 30 Hz
(C) 60 Hz
(D) 120 Hz
104. Metallic copper is a:
(A) Paramagnetic substance
(B) Diamagnetic substance
(C) Ferromagnetic substance
(D) Ferrimagnetic substance
105. A Transformer rated 250 kVA, 4160 V / 480 V, 60 Hz has an impedance of 5.1%. Calculate the total impedance of the transformer referred to the primary side.
(A) 69 ohm
(B) 0.92 ohm
(C) 3.52 ohm
(D) 0.51 ohm
106. What is peak factor of a sinusoidal wave?
(A) 1.11
(B) 1.414
(C) 3.142
(D) 4.44
107. What does the maximum Surge current rating of an SCR specify?
(A) Repetitive current with sine wave.
(B) Non-repetitive current with rectangular wave.
(C) Non-repetitive current with sine wave.
(D) Repetitive current with rectangular wave.
108. A Power system has a total load of 1260 MW at 50 Hz. The load varies 1.5% for every 1% change in frequency. Find the steady state frequency deviation, when a 60 MW load is suddenly dripped if there is no speed control.
(A) 1.667 Hz
(B) 50 Hz
(C) No change
(D) 3.32 Hz
109. A practical voltage source consists of an ideal voltage source in
(A) Series with internal resistance
(B) Parallel with internal resistance
(C) Series with impedance
(D) Series with capacitance

110. The per unit impedance of a circuit element is 0.30. If the base kV and base MVA are halved, then the new value of the per unit impedance of the circuit element will be:
- (A) 0.3
 - (B) 0.6
 - (C) 0.003
 - (D) 0.006
111. What does the region around the stationary electric charge has?
- (A) Electric field
 - (B) Magnetic field
 - (C) Semi permeable region
 - (D) Insulating field
112. What language is understood by 'Micro Processor'?
- (A) Binary
 - (B) Fortran
 - (C) Instruction
 - (D) C++
113. A ramp voltage $V(t)=100$ V is applied to an RC differentiating circuit with $R=5$ k Ω and $C=4$ μ F. The maximum output voltage is
- (A) 0.2 V
 - (B) 2 V
 - (C) 10 V
 - (D) 50 V
114. What is the Output voltage of Op-amp for input voltage of $V_{i1}=150$ μ V, $V_{i2}=140$ μ V if the amplifier has differential gain of $A_d=4000$ and value of CMRR is 100.
- (A) 45.8 mV
 - (B) 40.006 mV
 - (C) 10 μ V
 - (D) 145 μ V
115. A large transformer operating at no load draws an exciting current I_o of 5A, when the primary is connected to a 120 V, 60 Hz source. From a wattmeter test, it is known that iron losses are equal to 180 W. Calculate the reactive power absorbed by the core.
- (A) 600 var
 - (B) 572 var
 - (C) 180 var
 - (D) 360 var
116. What is the time constant of an RC series circuit?
- (A) R/C
 - (B) C/R
 - (C) 1/RC
 - (D) RC
117. RMS value of rectangular wave of period T, having a value of +V for a duration $T_1(<T)$ and -V for the duration $T-T_1=T_2$ equals
- (A) V
 - (B) T_1-T_2 / T
 - (C) $V / \sqrt{2}$
 - (D) T_1 / T_2
118. An energy meter has a constant of 600 rev/kWh. If the meter makes 10 revolutions in 20 s, what is the load in kW?
- (A) 0.75 kW
 - (B) 1.5 kW
 - (C) 3 kW
 - (D) 6 kW
119. Signal flow graph is a
- (A) Polar plot
 - (B) Bode plot
 - (C) Topological representation of set of differential equations
 - (D) Truth table
120. When 'n' resistances each of value 'r' are connected in parallel, then the resultant resistance is 'x'. When these 'n' resistances are connected in series, total resistance is
- (A) n^2X
 - (B) X/n
 - (C) n^2/X
 - (D) nX^2

121. In case of four pole, lap wound machine if the air gap under each pole is the same, then what will be the result?
- There will be reduced eddy currents
 - There will be reduced hysteresis loss
 - Current in each path will not be the same
 - It will result in higher terminal voltage
122. The technique of using stair case ramp in DVM (Digital Volt Meter) is called
- Deflecting torque technique
 - Null balancing technique
 - Controlling torque technique
 - Detaching torque technique
123. What type of excitation is given to the rotor winding of a synchronous motor?
- DC supply at 100 -250 V
 - AC supply at 400 V
 - Revolving field
 - Induction from stator currents
124. The power in a 3phase circuit is measured with the help of 2 wattmeters. The reading of one of wattmeters is positive and that of the others is negative. The magnitude of readings is different. It can be concluded that the power factor of the circuit is
- Unity
 - 2 (lagging)
 - 5 (lagging)
 - Less than 0.5 (lagging)
125. What is the decimal equivalent of hexa decimal no (8A6)?
- 1422
 - 1242
 - 2122
 - 2214
126. The phase voltages across a certain load are given as $V_a = (176 - j132) V$, $V_b = (-128-j96) V$ and $V_c = (-160 +j100) V$. Compute positive sequence component of voltage.
- 0
 - $163.24-j35.1 V$
 - $50.1-j53.9 V$
 - $25.1-j53.9 V$
127. What is the equivalent resistance of a network having 5 resistors of each 10ohm connected in parallel?
- 10 Ohms
 - 50 Ohms
 - 500 Ohms
 - 2 Ohms
128. Which of the following gate is inverted OR gate?
- NAND
 - NOR
 - AND
 - EX-OR
129. A 16 kV DC source having an internal resistance of 1 ohm supplies 900A to a 12 kV, 3 phase 6 pulse 60 Hz inverter. Calculate the DC voltage generated by the inverter.

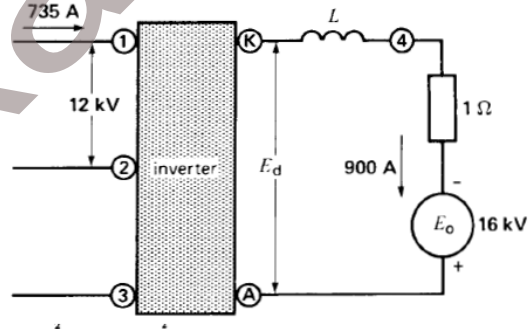

- 27000 V
 - 15100 V
 - 16000 V
 - 16400 V
130. What does the discharge transistor do in the 555 timer circuit?
- Discharge the external capacitor to stop the timing
 - Charge the external capacitor to stop the timing
 - Discharge the external capacitor to start the timing over again
 - Charge the external capacitor to start the timing over again

131. The usual value of slip of a 3 Φ induction motor at full load is about:
- (A) 0.05
(B) 0.1
(C) 0.3
(D) 0.8
132. One 200 KVA transformer has an iron loss of 1 KW and full load Cu loss of 2 KW. Its load KVA corresponding to maximum efficiency is:
- (A) 100 KVA
(B) 141.4 KVA
(C) 50 KVA
(D) 200 KVA
133. The generator shown in the figure rotates at 6000 r/min and generates an effective sinusoidal voltage of 170 V per winding. Calculate the output frequency.

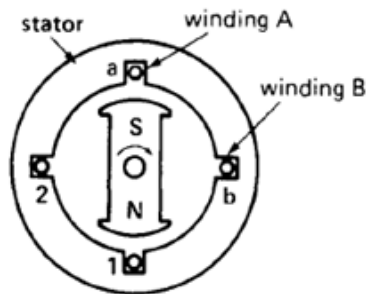

- (A) 100 Hz
(B) 10 Hz
(C) 1 Hz
(D) 1 kHz
134. An electromechanical closed-loop control system has the transfer function $C(s)/R(s) = k/s(s^2 + s + 1)(s + 4) + k$. Which one of the following is correct?
- (A) The system is stable for all positive values of k
(B) The system is unstable for all values of k
(C) The system is stable for values of k between zero and 3.36
(D) The system is stable for values of k between 1.6 and 2.45
135. Three resistors of 4 Ω , 6 Ω and 9 Ω are connected in parallel. Which resistor consumes the maximum power?
- (A) 4 Ω
(B) 6 Ω
(C) 9 Ω
(D) 17 Ω
136. For a class A operation, the biasing resistor should be adjusted such that
- (A) Q-point never lies
(B) Q-point lies in the middle of the load line
(C) Q-point lies in the cut off region
(D) Q-point lies on the operating region
137. A three phase 50 Hz, 400 kV transmission line is 300 km long. The line inductance is 0.97 mH/km per phase and capacitance is 0.0115 mF/km per phase. Assume a loss less line. Determine the line wavelength (a line phase constant).
- (A) 1250 km
(B) 6578 km
(C) 4990 km
(D) 2445 km
138. What happens when the shunt resistance of a galvanometer circuit is increased?
- (A) Its current sensitivity increases.
(B) Its current sensitivity decreases.
(C) It's damping increases.
(D) It's controlling torque increases.
139. FET belongs to which of the following type of device?
- (A) Current controlled device
(B) Magnetic device
(C) Power controlled device
(D) Voltage controlled device
140. What is the most effective way to reduce the cost of power generation in a power station?
- (A) By increasing the diversity factor and decreasing the load factor
(B) By increasing both the diversity factor and the load factor
(C) By decreasing both the diversity factor and the load factor
(D) By decreasing the diversity factor and increasing the load factor

141. Which among the following is the dual of Boolean expression $X+YZ=(X+Y)(X+Z)$?
- (A) $X(Y+Z)=XY+YZ$
 (B) $X.(Y+Z)=X.Y+X.Z$
 (C) $X+(Y+Z) = X.Y+Z$
 (D) $X+(YZ) = X+Y+Z$
142. A Phase shift transformer is designed to control 150 MVA on a 230 kV, 3 phase line. The phase angle is variable between zero and ± 15 deg. Calculate the approximate basic power rating of the transformer.
- (A) 150 MVA
 (B) 56 MVA
 (C) 75 MVA
 (D) 750 MVA
143. A DC shunt generator supplies 450 A at 230 V. The resistances of shunt field and armature are 50Ω and 0.025Ω respectively. What will be the armature voltage drop?
- (A) 11.24 V
 (B) 22.7 V
 (C) 31.6 V
 (D) 38.4 V
144. For a two port symmetric bilateral network, if $A = 3\Omega$ and $B = 1\Omega$, the value of parameter C will be
- (A) 4s
 (B) 6s
 (C) 8s
 (D) 16s
145. What is the power factor of a cable of loss angle " ϵ "?
- (A) $\sin \epsilon$
 (B) $\cos \epsilon$
 (C) $\tan \epsilon$
 (D) Independent of ϵ
146. A 1mA D' Arsonval movement has resistance of 100Ω . It is to be converted to a 10 V voltmeter. The value of multiplier resistance is
- (A) 999 Ω
 (B) 9999 Ω
 (C) 9900 Ω
 (D) 990 Ω

147. If $\alpha=0.995$, $I_E=10$ mA and $I_{CO}=0.5$ mA, then I_{CEO} will be
- (A) 100 μA
 (B) 25 μA
 (C) 10.1 μA
 (D) 10.5 μA
148. Maximum power developed in a synchronous motor occurs at a coupling angle of:
- (A) 120°
 (B) 60°
 (C) 90°
 (D) 0°
149. The AC source shown in the figure has an effective voltage of 120 V, 60 Hz. The load draws a DC current of 20 A. Calculate the average DC current in each diode.

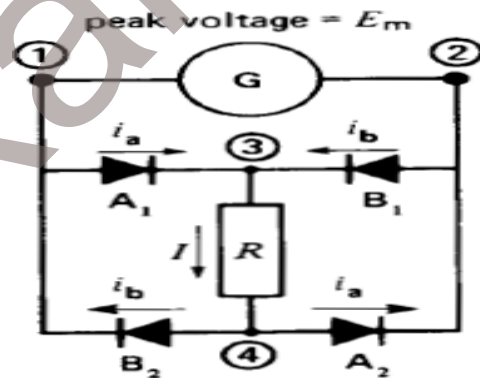

- (A) 5 A
 (B) 10 A
 (C) 20 A
 (D) 0
150. Calculate the power loss, if power generated by two plants are $P_1=50$ MW and $P_2 =40$ MW and the loss coefficients are $B_{11}=0.001$, $B_{22}=0.0025$ and $B_{12}=-0.0005$.
- (A) 4.5 MW
 (B) 5.5 MW
 (C) 6.5 MW
 (D) 8.5 MW

Space for Rough work:

SarkariExam.com